



# EPOCH 6LT

## Ultrasonic Flaw Detector

### User's Manual

DMTA-10083-01EN — Rev. 4  
September 2017

This instruction manual contains essential information on how to use this Olympus product safely and effectively. Before using this product, thoroughly review this instruction manual. Use the product as instructed. Keep this instruction manual in a safe, accessible location.

Olympus Scientific Solutions Americas, 48 Woerd Avenue, Waltham, MA 02453, USA

Copyright © 2017 by Olympus. All rights reserved. No part of this publication may be reproduced, translated, or distributed without the express written permission of Olympus.

This document was prepared with particular attention to usage to ensure the accuracy of the information contained therein, and corresponds to the version of the product manufactured prior to the date appearing on the title page. There could, however, be some differences between the manual and the product if the product was modified thereafter.

The information contained in this document is subject to change without notice.

Part number: DMTA-10083-01EN

Rev. 4

September 2017

Printed in the United States of America

All brands are trademarks or registered trademarks of their respective owners and third party entities.

---

---

# Table of Contents

---

<b>List of Abbreviations .....</b>	<b>vii</b>
<b>Labels and Symbols .....</b>	<b>1</b>
<b>Important Information – Please Read Before Use .....</b>	<b>5</b>
Intended Use .....	5
Instruction Manual .....	5
Instrument Compatibility .....	6
Repair and Modification .....	6
Safety Symbols .....	7
Safety Signal Words .....	7
Note Signal Words .....	8
Safety .....	8
Warnings .....	9
Battery Precautions .....	10
Equipment Disposal .....	11
CE (European Community) .....	11
WEEE Directive .....	11
China RoHS .....	11
Korea Communications Commission (KCC) .....	13
EMC Directive Compliance .....	13
FCC (USA) Compliance .....	13
ICES-001 (Canada) Compliance .....	14
Warranty Information .....	14
Technical Support .....	15
<b>Introduction .....</b>	<b>17</b>
<b>1. Package Content .....</b>	<b>19</b>

1.1	Unpacking the Instrument .....	19
1.2	Case Contents .....	19
1.3	EPOCH 6LT Flaw Detector Components .....	20
1.4	Standard Accessories .....	21
1.4.1	Battery .....	21
1.4.2	AC Charger/Adaptor .....	21
1.4.3	USB Data Cable .....	23
1.4.4	USB Drive .....	23
1.5	Optional Accessories .....	23
1.5.1	Charging Base .....	24
1.5.2	Battery Conditioning .....	25
<b>2.</b>	<b>Overview .....</b>	<b>27</b>
2.1	External Connectors .....	27
2.1.1	AC Adaptor Connector .....	28
2.1.2	LEMO Transducer Connectors .....	28
2.2	Battery Compartment .....	28
2.3	Data Port .....	29
2.3.1	Digital Video Connector .....	30
2.3.2	USB A Connector .....	30
2.3.3	Mini USB connector .....	30
2.3.4	Reset Switch .....	30
2.3.5	Accessory Mount .....	30
2.3.6	Wrist Strap Mounts .....	31
2.4	Keys, Knob, and Indicators .....	31
2.4.1	Power Key .....	32
2.4.2	Power Indicator .....	32
2.4.3	Shift Key .....	32
2.4.4	Escape Key .....	33
2.4.5	Enter Key .....	33
2.4.6	Tab Key .....	33
2.4.7	Adjustment Knob .....	33
<b>3.</b>	<b>Operation .....</b>	<b>35</b>
3.1	Turning On the Instrument .....	35
3.2	Turning Off the Instrument .....	35
3.3	Connecting the AC Charger/Adaptor .....	36
3.4	Opening the Data Port Cover .....	37
<b>4.</b>	<b>Maintenance and Troubleshooting .....</b>	<b>39</b>
4.1	Battery Replacement .....	39

4.2	Instrument Cleaning .....	42
4.3	Seal Verification .....	42
4.4	Display Protection .....	42
4.5	Annual Calibration .....	42
4.6	Troubleshooting .....	43
<b>Appendix A: Specifications .....</b>		<b>45</b>
<b>Appendix B: Parts List .....</b>		<b>49</b>
<b>List of Figures .....</b>		<b>51</b>
<b>List of Tables .....</b>		<b>53</b>
<b>Index .....</b>		<b>55</b>



---

## List of Abbreviations

---

EFUP	environment-friendly use period
IP	International Protection (or ingress protection)
Li-ion	lithium-ion
UI	user interface





---

## Labels and Symbols

---

A safety-related label and symbols are attached to the instrument at the location shown in Figure i-1 on page 1. If the label or symbols are missing or illegible, please contact Olympus.



Location of the rating label (see Table 1 on page 2)

**Figure i-1 Labels location**

**Table 1 Content of the rating label**

Item	Description
	<p>The CE marking is a declaration that this product conforms to all the applicable directives of the European Community. See the <i>Declaration of Conformity</i> for details. Contact your Olympus representative for more information.</p>
	<p>The regulatory compliance mark (RCM) label indicates that the product complies with all applicable standards, and has been registered with the Australian Communications and Media Authority (ACMA) for placement on the Australian market.</p>
	<p>The WEEE symbol indicates that the product must not be disposed of as unsorted municipal waste, but should be collected separately.</p>

**Table 1 Content of the rating label (continued)**





	<p>The China RoHS mark indicates the product's Environment-Friendly Use Period (EFUP). The EFUP is defined as the number of years for which listed controlled substances will not leak or chemically deteriorate while in the product. The EFUP for the EPOCH 6LT has been determined to be 15 years. <b>Note:</b> The Environment-Friendly Use Period (EFUP) is not meant to be interpreted as the period assuring functionality and product performance.</p>
	<p>Seller and user shall be noticed that this equipment is suitable for electromagnetic equipment for office work (class A) and it can be used outside home.</p> <p>The MSIP code for the EPOCH 6LT is the following: MSIP-REM-OYN-EP6LT.</p>
	<p>Efficiency of battery chargers specific to California, USA.</p>
	<p>The DC adaptor polarity symbol.</p>

Table 1 Content of the rating label (*continued*)

<p><b>SERIAL</b></p>	<div data-bbox="532 180 1099 386" style="border: 1px solid black; padding: 10px; margin-bottom: 10px;"> <p><b>SERIAL</b> <span style="border: 1px solid black; padding: 2px 10px;">yynnnddmm</span></p>  </div> <p>The serial number is a nine (9) digit number in the following format:</p> <p style="text-align: center;"><b>yynnnddmm</b></p> <p>where:</p> <p><b>yy</b> Production year  <b>nnn</b> Unit number manufactured that day  <b>dd</b> Production day  <b>mm</b> Production Month</p> <p>For example, the 080011612 serial number indicates that the first unit (001) was produced on the December 16, 2008.</p>
----------------------	--



**CAUTION**



To avoid the risk of electric shock, do not touch the inner conductor of the LEMO connectors. Up to 400 V can be present on the inner conductor. The warning symbol shown in the figure below warns of this electric shock risk.

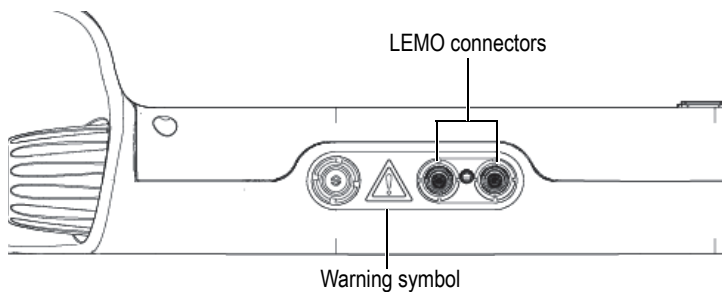

---

## Important Information — Please Read Before Use

---

### Intended Use

The EPOCH 6LT is designed to perform nondestructive inspections on industrial and commercial materials.



#### **WARNING**

Do not use the EPOCH 6LT for any purpose other than its intended use. It must never be used to inspect or examine human or animal body parts.

---

### Instruction Manual

This instruction manual contains essential information on how to use this Olympus product safely and effectively. Before using this product, thoroughly review this instruction manual. Use the product as instructed.

Keep this instruction manual in a safe, accessible location.

---

**IMPORTANT**

Some of the details of components and/or software images in this manual may differ from your instrument's components or software display. However, the principles remain the same.

---

## Instrument Compatibility

The EPOCH 6LT is primarily a self-contained unit. However, it does have a series of I/O ports that can be used to connect compatible peripherals and connect it to a PC. The unit derives its required DC input power from the EPOCH 6LT AC adaptor or battery pack.

---



**CAUTION**

Always use equipment and accessories that meet Olympus specifications. Using incompatible equipment could cause equipment malfunction and/or damage, or human injury.

---

## Repair and Modification

The EPOCH 6LT does not contain any user-serviceable parts. Opening the instrument might void the warranty.

---



**CAUTION**

In order to prevent human injury and/or equipment damage, do not disassemble, modify, or attempt to repair the instrument.

---

## Safety Symbols

The following safety symbols might appear on the instrument and in the instruction manual:



General warning symbol

This symbol is used to alert the user to potential hazards. All safety messages that follow this symbol shall be obeyed to avoid possible harm or material damage.



Shock hazard caution symbol

This symbol is used to alert the user to potential electric shock hazards. All safety messages that follow this symbol shall be obeyed to avoid possible harm.

## Safety Signal Words

The following safety signal words might appear in the documentation of the instrument:



**DANGER**

The DANGER signal word indicates an imminently hazardous situation. It calls attention to a procedure, practice, or the like that if not correctly performed or adhered to will result in death or serious personal injury. Do not proceed beyond a DANGER signal word until the indicated conditions are fully understood and met.



**WARNING**

The WARNING signal word indicates a potentially hazardous situation. It calls attention to a procedure, practice, or the like that if not correctly performed or adhered to could result in death or serious personal injury. Do not proceed beyond a WARNING signal word until the indicated conditions are fully understood and met.



## CAUTION

The CAUTION signal word indicates a potentially hazardous situation. It calls attention to a procedure, practice, or the like that if not correctly performed or adhered to may result in minor or moderate personal injury, material damage, particularly to the product, destruction of part or all of the product, or loss of data. Do not proceed beyond a CAUTION signal word until the indicated conditions are fully understood and met.

## Note Signal Words

The following note signal words could appear in the documentation of the instrument:

### IMPORTANT

The IMPORTANT signal word calls attention to a note that provides information that is important or essential to the completion of a task.

### NOTE

The NOTE signal word calls attention to an operating procedure, practice, or the like, that requires special attention. A note also denotes related parenthetical information that is useful, but not imperative.

### TIP

The TIP signal word calls attention to a type of note that helps you apply the techniques and procedures described in the manual to your specific needs, or that provides hints on how to effectively use the capabilities of the product.

## Safety

Before turning on the instrument, verify that the correct safety precautions have been taken (see the following warnings). In addition, note the external markings on the instrument, which are described under “Safety Symbols.”



## Warnings



### WARNING

#### General Warnings

- Carefully read the instructions contained in this instruction manual prior to turning on the instrument.
- Keep this instruction manual in a safe place for further reference.
- Follow the installation and operation procedures.
- It is imperative to respect the safety warnings on the instrument and in this instruction manual.
- If the equipment is used in a manner not specified by the manufacturer, the protection provided by the equipment could be impaired.
- Do not install substitute parts or perform any unauthorized modification to the instrument.
- Service instructions, when applicable, are for trained service personnel. To avoid the risk of electric shock, do not perform any work on the instrument unless qualified to do so. For any problem or question regarding this instrument, contact Olympus or an authorized Olympus representative.
- Do not touch the connectors directly by hand. Otherwise, a malfunction or electric shock may result.
- Do not allow metallic or foreign objects to enter the device through connectors or any other openings. Otherwise, a malfunction or electric shock may result.



### CAUTION

If an unauthorized power supply cord is used to power the instrument or charge the batteries, Olympus cannot guarantee the electrical safety of the equipment.

## Battery Precautions



### CAUTION

- Before disposing of a battery, check your local laws, rules, and regulations, and follow them accordingly.
- Transportation of lithium-ion batteries is regulated by the United Nations under the United Nations Recommendations on the Transport of Dangerous Goods. It is expected that governments, intergovernmental organizations, and other international organizations shall conform to the principles laid down in these regulations, thus contributing to worldwide harmonization in this field. These international organizations include the International Civil Aviation organization (ICAO), the International Air Transport Association (IATA), the International Maritime Organization (IMO), the US Department of Transportation (USDOT), Transport Canada (TC), and others. Please contact the transporter and confirm current regulations before transportation of lithium-ion batteries.
- For California (USA) only:  
The CR battery contains perchlorate material, and special handling may be required. Refer to <http://www.dtsc.ca.gov/hazardouswaste/perchlorate>.
- Do not open, crush, or perforate batteries; doing so could cause injury.
- Do not incinerate batteries. Keep batteries away from fire and other sources of extreme heat. Exposing batteries to extreme heat (over 80 °C) could result in an explosion or personal injury.
- Do not drop, hit, or otherwise abuse a battery, as doing so could expose the cell contents, which are corrosive and explosive.
- Do not short-circuit the battery terminals. A short circuit could cause injury and severe damage to a battery making it unusable.
- Do not expose a battery to moisture or rain; doing so could cause an electric shock.
- Only use the EPOCH 6LT unit or an external charger approved by Olympus to charge the batteries.
- Only use batteries supplied by Olympus.
- Do not store batteries that have less than 40 % remaining charge. Recharge batteries to between 40 % and 80 % capacity before storing them.
- During storage, keep the battery charge between 40 % and 80 %.
- Do not leave batteries in the EPOCH 6LT unit during instrument storage.

## Equipment Disposal

Before disposing of the EPOCH 6LT, check your local laws, rules, and regulations, and follow them accordingly.

### CE (European Community)



This device complies with the requirements of both directive 2014/30/EU concerning electromagnetic compatibility and directive 2014/35/EU concerning low voltage. The CE marking indicates compliance with the above directives.

### WEEE Directive



In accordance with European Directive 2012/19/EU on Waste Electrical and Electronic Equipment (WEEE), this symbol indicates that the product must not be disposed of as unsorted municipal waste, but should be collected separately. Refer to your local Olympus distributor for return and/or collection systems available in your country.

### China RoHS

*China RoHS* is the term used by industry generally to describe legislation implemented by the Ministry of Information Industry (MII) in the People's Republic of China for the control of pollution by electronic information products (EIP).



The China RoHS mark indicates the product's Environment-Friendly Use Period (EFUP). The EFUP is defined as the number of years for which listed controlled substances will not leak or chemically deteriorate while in the product. The EFUP for the EPOCH 6LT has been determined to be 15 years.

**Note:** The Environment-Friendly Use Period (EFUP) is not meant to be interpreted as the period assuring functionality and product performance.

“中国 RoHS”是一个工业术语，一般用于描述中华人民共和国信息工业部（MII）针对控制电子信息产品（EIP）的污染所实行的法令。



电气电子产品  
有害物质  
限制使用标识

中国 RoHS 标识是根据“电器电子产品有害物质限制使用管理办法”以及“电子电气产品有害物质限制使用标识要求”的规定，适用于在中国销售的电气电子产品上的电气电子产品有害物质限制使用标识。

**注意：**电气电子产品有害物质限制使用标识内的数字为在正常的使用条件下有害物质不会泄漏的年限，不是保证产品功能性的年限。

产品中有害物质的名称及含量

部件名称		有害物质					
		铅及其化合物 (Pb)	汞及其化合物 (Hg)	镉及其化合物 (Cd)	六价铬及其化合物 (Cr(VI))	多溴联苯 (PBB)	多溴二苯醚 (PBDE)
主体	机构部件	×	○	○	○	○	○
	光学部件	×	○	○	○	○	○
	电气部件	×	○	○	○	○	○
附件		×	○	○	○	○	○

本表格依据 SJ/T 11364 的规定编制。

○：表示该有害物质在该部件所有均质材料中的含量均在 GB/T26572 规定的限量要求以下。

×：表示该有害物质至少在该部件的某一均质材料中的含量超出 GB/T26572 规定的限量要求。

## **Korea Communications Commission (KCC)**

이 기기는 업무용 환경에서 사용할 목적으로 적합성평가를 받은 기기로서 가정용 환경에서 사용하는 경우 전파간섭의 우려가 있습니다.

## **EMC Directive Compliance**

This equipment generates and uses radio-frequency energy and, if not installed and used properly (that is, in strict accordance with the manufacturer's instructions), may cause interference. The EPOCH 6LT has been tested and found to comply with the limits for an industrial device in accordance with the specifications of the EMC directive.

## **FCC (USA) Compliance**

This device complies with Part 15 of the FCC Rules. Operation is subject to the following two conditions:

1. This device may not cause harmful interference.
2. This device must accept any interference received, including interference that may cause undesired operation.

Changes or modifications not expressly approved by the party responsible for compliance could void the user's authority to operate the equipment.

This equipment has been tested and found to comply with the limits for a Class A digital device, pursuant to Part 15 of the FCC Rules. These limits are designed to provide reasonable protection against harmful interference when the equipment is operated in a commercial environment. This equipment generates, uses, and can radiate radio frequency energy, and if not installed and used in accordance with the instruction manual, might cause harmful interference to radio communications. Operation of this equipment in a residential area is likely to cause harmful interference, in which case you will be required to correct the interference at your own expense.

## ICES-001 (Canada) Compliance

This Class A digital apparatus complies with Canadian ICES-001.

Cet appareil numérique de la classe A est conforme à la norme NMB-001 du Canada.

## Warranty Information

Olympus guarantees your Olympus product to be free from defects in materials and workmanship for a specific period, and in accordance with conditions specified in the *Olympus Scientific Solutions Americas Inc. Terms and Conditions* available at <http://www.olympus-ims.com/en/terms/>.

The Olympus warranty only covers equipment that has been used in a proper manner, as described in this instruction manual, and that has not been subjected to excessive abuse, attempted unauthorized repair, or modification.

Inspect materials thoroughly on receipt for evidence of external or internal damage that might have occurred during shipment. Immediately notify the carrier making the delivery of any damage, because the carrier is normally liable for damage during shipment. Retain packing materials, waybills, and other shipping documentation needed in order to file a damage claim. After notifying the carrier, contact Olympus for assistance with the damage claim and equipment replacement, if necessary.

This instruction manual explains the proper operation of your Olympus product. The information contained herein is intended solely as a teaching aid, and shall not be used in any particular application without independent testing and/or verification by the operator or the supervisor. Such independent verification of procedures becomes increasingly important as the criticality of the application increases. For this reason, Olympus makes no warranty, expressed or implied, that the techniques, examples, or procedures described herein are consistent with industry standards, nor that they meet the requirements of any particular application.

Olympus reserves the right to modify any product without incurring the responsibility for modifying previously manufactured products.

## Technical Support

Olympus is firmly committed to providing the highest level of customer service and product support. If you experience any difficulties when using our product, or if it fails to operate as described in the documentation, first consult the user's manual, and then, if you are still in need of assistance, contact our After-Sales Service. To locate the nearest service center, visit the Service Centers page at: <http://www.olympus-ims.com>.





---

## Introduction

---

The EPOCH 6LT is a portable ultrasonic nondestructive testing (NDT) instrument designed primarily for inspections requiring high portability, such as rope access, and detection of flaw conditions in welds, pipes, turbine blades, and other structural and industrial materials. The instrument can be used both indoors and outdoors.

The EPOCH 6LT offers advanced conventional ultrasonic performance featuring a large dynamic range and superior measurement resolution. The full color liquid-crystal display provides a resolution of  $640 \times 480$  pixels with transreflective technology for superior visibility. The software user interface (UI) provides an intuitive way to access the full functionality of the instrument.

Before you operate the EPOCH 6LT, Olympus recommends that you have a thorough understanding of the principles and limitations of ultrasonic nondestructive testing and that you seek adequate training. Olympus assumes no responsibility for incorrect operational procedure or misinterpretation of test results.

Although the EPOCH 6LT continuously self-calibrates, you must be aware of the regulatory requirements. Olympus offers calibration and documentation services. Contact Olympus or your local representative with any special requests.



---

# 1. Package Content

---

A complete EPOCH 6LT package consists of a handheld ultrasonic flaw detector and several key accessories.

## 1.1 Unpacking the Instrument

The EPOCH 6LT ultrasonic flaw detector and accessories are shipped in an industrial transport case.

### To unpack the instrument

1. Open the transport case, then locate the shipping papers, documentation, and USB drive, and then remove them from the case.
2. Remove the EPOCH 6LT and all of the accessories.
3. Inspect the EPOCH 6LT and all accessories for damage, and report any problems to Olympus immediately.

## 1.2 Case Contents

The EPOCH 6LT comes standard with several key accessories:

- AC charger/adaptor with power cord (varies by outlet configuration)
- *EPOCH 6LT Ultrasonic Flaw Detector Getting Started Guide*
- USB drive containing the *EPOCH 6LT Ultrasonic Flaw Detector User's Manual*
- USB cable
- Wrist strap

For a complete parts list, see "EPOCH 6LT basic kit" on page 49.

## 1.3 EPOCH 6LT Flaw Detector Components

The following table lists the EPOCH 6LT ultrasonic flaw detector components (see Table 2 on page 20).

**Table 2 EPOCH 6LT ultrasonic flaw detector components**

Component key		EPOCH 6LT – All models
<b>EPOCH 6LT (front)</b>		
1	Adjustment knob	
2	User interface display	
3	Tab button	
4	Enter button	
5	Escape button	
6	Shift (2nd function) button	
7	Power indicator	
8	Power button	
<b>EPOCH 6LT (top)</b>		
9	Data Port access cover	
10	Transducer connectors	
11	AC adaptor connector (12 VDC)	
<b>EPOCH 6LT (bottom)</b>		
12	Battery compartment cover	
13	Accessory mount	

## 1.4 Standard Accessories

The EPOCH 6LT comes with the following standard accessories:

- Lithium-ion (Li-ion) battery
- AC power adaptor
- USB data cable
- USB drive containing the user documentation.

### 1.4.1 Battery

The EPOCH 6LT comes standard with one removable lithium-ion (Li-ion) battery (see Figure 1-1 on page 21).



Figure 1-1 EPOCH 6LT Li-ion battery

### 1.4.2 AC Charger/Adaptor

The AC charger/adaptor (see Figure 1-2 on page 22) can be used to power the EPOCH 6LT when an AC mains outlet is available. The AC charger/adaptor is for indoor use only. If a Li-ion battery is installed in the instrument, and the AC charger/adaptor is connected, the battery charges until full.



**Figure 1-2 AC charger/adaptor**

Region specific power cords are available for use with the AC charger/adaptor (see Figure 1-2 on page 22). Make sure that the power cord included with your EPOCH 6LT is appropriate for your region. See Table 3 on page 22 for more information.

**Table 3 Region specific power cord options**

Region	Plug	U8 Number
Australia	Type I	U8840005
Brazil	Type J	U8769007
China	Type I	U8769008
Denmark	Type K	U8840011
European	Type F	U8840003
Italy	Type L	U8840009
Japan	Type B	U8767383
South Africa, Hong Kong, India, Pakistan	Type D/M	U8840013
South Korea	Type F	U8769009

**Table 3 Region specific power cord options (continued)**

Region	Plug	U8 Number
UK	Type G	U8840007
USA	Type B	U8840015

### 1.4.3 USB Data Cable

The EPOCH 6LT flaw detector comes standard with one USB data cable. This cable provides you the ability to connect the EPOCH 6LT to a PC and transfer information into or out of the instrument (see Figure 1-3 on page 23). The USB data cable must have one L20 ferrite bead on each end of the cable to be CE compliant.

**Figure 1-3 USB data cable**

### 1.4.4 USB Drive

The EPOCH 6LT comes standard with a USB drive that is loaded with the *EPOCH 6LT Ultrasonic Flaw Detector User's Manual*. The USB drive can also be used to store test data.

## 1.5 Optional Accessories

The optional accessories for the EPOCH 6LT are the following:

- External charging base
- Display protectors (10 pack)
- Rope access accessory kit
- Chest harness
- Desktop stand

For a complete list of the optional accessories, see “EPOCH 6LT optional accessories” on page 49.

## 1.5.1 Charging Base

The external charging base charges a Li-ion battery that has been removed from the EPOCH 6LT. The charging base is useful if you usually operate the EPOCH 6LT without connecting the AC charger/adaptor. See Table 4 on page 24 for a list of the charging base’s components.

**Table 4 EPOCH 6LT charging base**

Component key		EPOCH 6LT – All models
<b>Charging base (back)</b>		
1	Input power socket (12 VDC)	

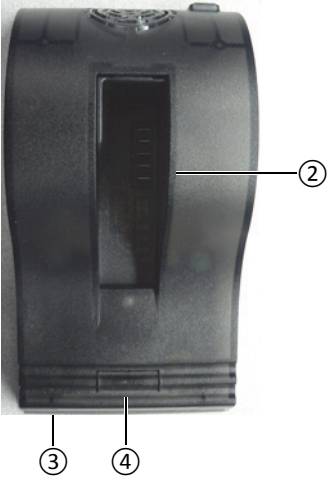

**Table 4 EPOCH 6LT charging base (continued)**

Component key		EPOCH 6LT – All models
<b>Charging base (top)</b>		
2	Charging base receptacle	
3	Battery charging indicator	
4	Battery conditioning button and discharge indicator	

**To operate the charging base**

1. Plug the AC charger/adaptor into the charging base's input power socket.
2. Align the Li-ion battery contacts with the contacts at the bottom of the charging base receptacle.
3. Firmly insert the Li-ion battery into the charging base receptacle.

**IMPORTANT**

Do not force the Li-ion battery into the charging base receptacle. Make sure that the battery contacts and receptacle contacts are properly aligned.

4. Leave the Li-ion battery in the charging base until the charging indicator changes from flashing green to steady green.

**1.5.2 Battery Conditioning**

You can condition the Li-ion battery to restore it to peak efficiency. Battery conditioning completely discharges the battery, then recharges it.

## To condition the battery

1. Firmly insert the battery into the charging base receptacle.
2. Press and hold the battery conditioning button for three seconds (see Table 4 on page 24).  
After you release the button, the blue discharge indicator begins flashing.
3. Leave the battery in the charging base during the entire discharge/charge cycle:
  - a) The discharge indicator flashes blue until the battery is fully discharged.
  - b) The charging indicator flashes green until the battery is fully charged.
  - c) The charging indicator glows steady green when the discharge/charge cycle is complete.

---

## 2. Overview

---

The EPOCH 6LT ultrasonic flaw detector has a complement of connections intended to maximize the usability of the instrument.

### 2.1 External Connectors

The external connectors are located at the top of the instrument (see Figure 2-1 on page 27).

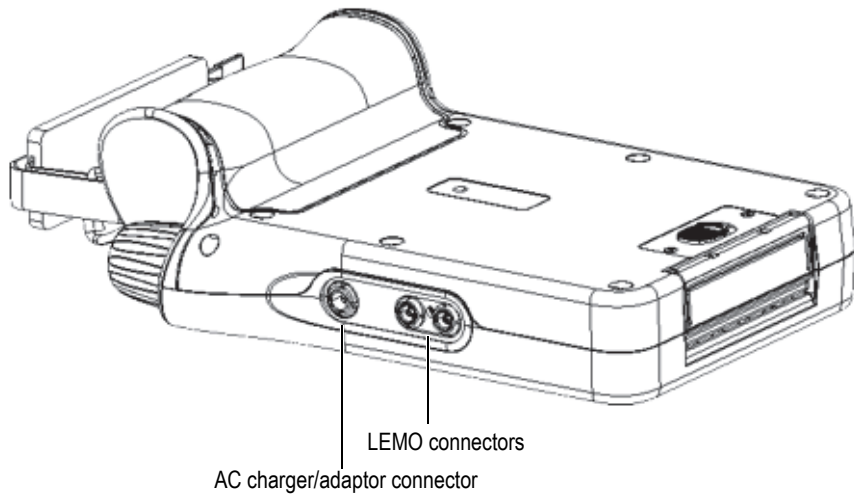

**Figure 2-1 External connectors**

## 2.1.1 AC Adaptor Connector

The AC charger/adaptor connects to the AC adaptor connector of the EPOCH 6LT to power the instrument and charge the battery.

## 2.1.2 LEMO Transducer Connectors

The EPOCH 6LT is supplied with sealed LEMO 00 transducer connectors. A center pin automatically identifies the connected transducer with certain Olympus corrosion dual element transducers.

The transducer connectors are color coded red and blue. When used with dual element transducers and in through-transmission modes, the red LEMO 00 connector acts as the transmit connector and the blue LEMO 00 connector acts as the receive connector.

---

<b>NOTE</b>
-------------

For single crystal pulse-echo inspections, you must connect the transducer to the red LEMO 00 (transmit) connector to send and receive a signal.

---

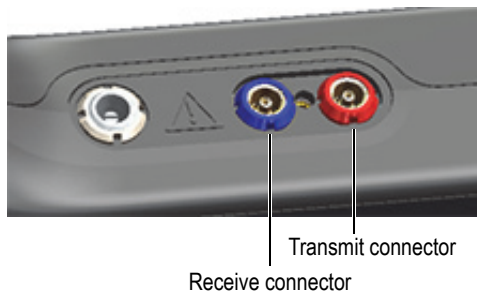

**Figure 2-2 Color-coded LEMO connectors**

## 2.2 Battery Compartment

The battery compartment cover is located at the bottom of the instrument (see Figure 2-3 on page 29).

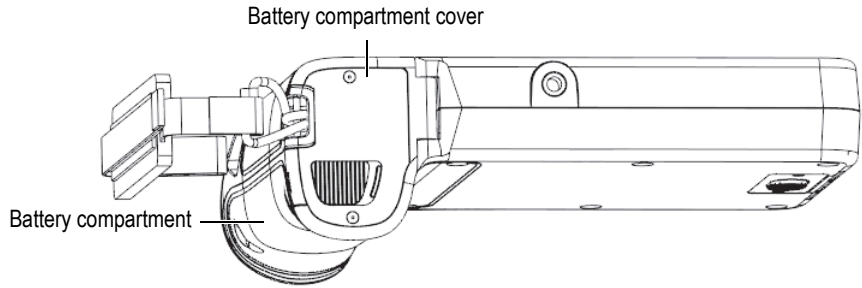
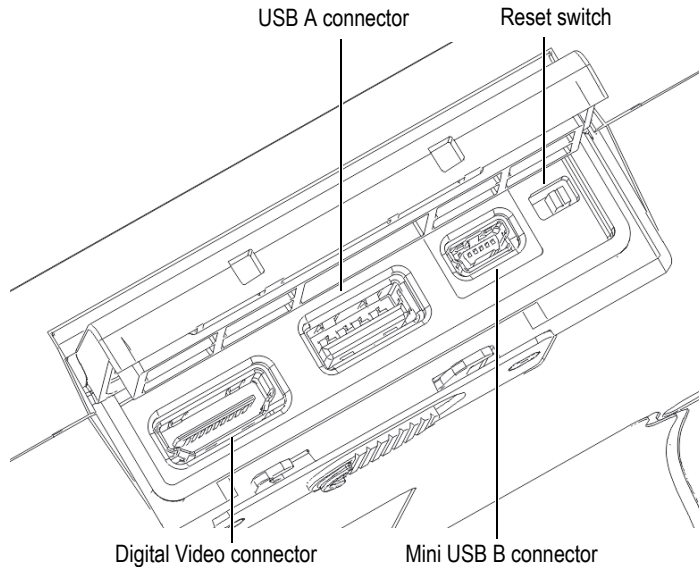

**Figure 2-3 Battery compartment—cover closed**

A sliding latch button opens the battery compartment cover and ensures the door is sealed when closed.

## 2.3 Data Port

The data port contains the EPOCH 6LT digital I/O connections and reset switch.



**Figure 2-4 Data port connectors and reset switch**

### 2.3.1 Digital Video Connector

The Digital Video connector is used to connect the EPOCH 6LT to an external digital display via a compatible cable (optional). The Digital Video cable must have one L20 ferrite bead on each end of the cable to be CE compliant.

### 2.3.2 USB A Connector

The USB A connector is used to connect the EPOCH 6LT to a USB storage device. The USB A connector must be used with the Olympus USB drive or equivalent to be CE compliant.

### 2.3.3 Mini USB connector

The mini USB connector is used to connect the EPOCH 6LT, via the supplied USB cable, to a PC for data transfer.

### 2.3.4 Reset Switch

The Reset switch is used to reset the system software in the event of a catastrophic software failure.

### 2.3.5 Accessory Mount

The accessory mount is a standard  $\frac{1}{4}$  in.-20 thread insert, which is located on the bottom of the instrument (see Figure 2-5 on page 30). Multiple mechanical accessories can be used with this mount, including the Olympus rope access accessory kit.

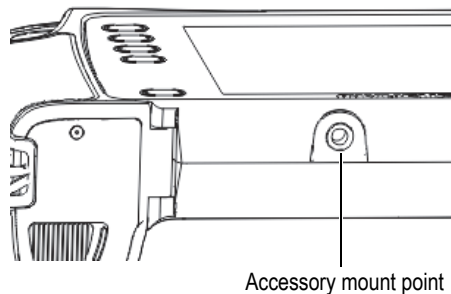

**Figure 2-5 Accessory mount**

### 2.3.6 Wrist Strap Mounts

The wrist strap mounts are located on the handle of the instrument (see Figure 2-6 on page 31). The EPOCH 6LT ships with the wrist strap mounted.

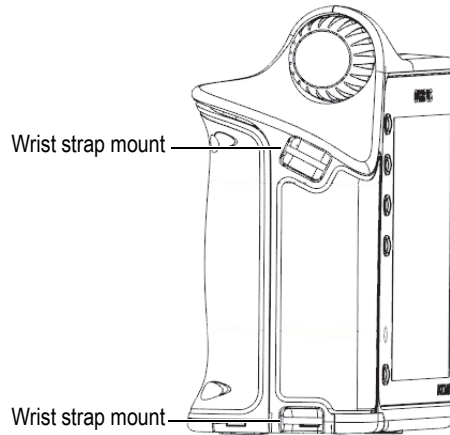

**Figure 2-6 Wrist strap mounts**

## 2.4 Keys, Knob, and Indicators

The keys and indicators are located on the front of the instrument. The adjustment knob is located on the left side of the instrument.



Figure 2-7 EPOCH 6LT front panel

### 2.4.1 Power Key

The Power key (  ) is used to turn on or off the instrument.

### 2.4.2 Power Indicator

The power indicator (  ) glows when power is applied to the instrument.

### 2.4.3 Shift Key

The Shift key (  ) is used to activate the second function, changing the way the ESC, Enter, and Tab keys function.



## 2.4.4 Escape Key

The ESC key (  ) is used to move the focus to the previous data field in the user interface (UI). The ESC > Shift key sequence changes the display mode of the UI.

## 2.4.5 Enter Key

The Enter key (  ) is used to accept a highlighted parameter (selected with the adjustment knob). The Shift > Enter key sequence switches between coarse and fine adjustment of the highlighted parameter with the adjustment knob.

## 2.4.6 Tab Key

The Tab key (  ) moves the focus to the next data field in the UI. The Shift > Tab key sequence enables you to navigate to the default Home screen in the UI.

## 2.4.7 Adjustment Knob

The adjustment knob increases or decreases the value of the highlighted adjustable parameter (see Figure 2-8 on page 33). The adjustment knob also allows scrolling/navigating through icons in the UI.

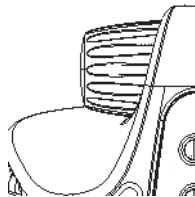

Figure 2-8 Adjustment knob



## 3. Operation

---

This chapter provides instructions for basic operational tasks. For information on the instrument software, refer to the user interface guide.

### 3.1 Turning On the Instrument

The EPOCH 6LT must have a battery inserted or be connected to AC power.

#### To turn on the instrument

- ◆ Press the Power key () to turn on the instrument.  
The software user interface (UI) initializes and displays.

### 3.2 Turning Off the Instrument

#### To turn off the instrument

- ◆ Press the Power key () to turn off the instrument.

### 3.3 Connecting the AC Charger/Adaptor

Connect the AC charger/adaptor directly to the EPOCH 6LT to power the instrument. When a Li-ion battery is installed in the instrument, and the AC charger/adaptor is connected, the battery charges until full. For information on charging the battery in the external charging base, see “Charging Base” on page 24. Note that the AC charger/adaptor is intended for indoor use only.

#### To connect the AC charger/adaptor

1. Plug the DC power plug into the AC charger/adaptor connector on the instrument (see Figure 3-1 on page 36).

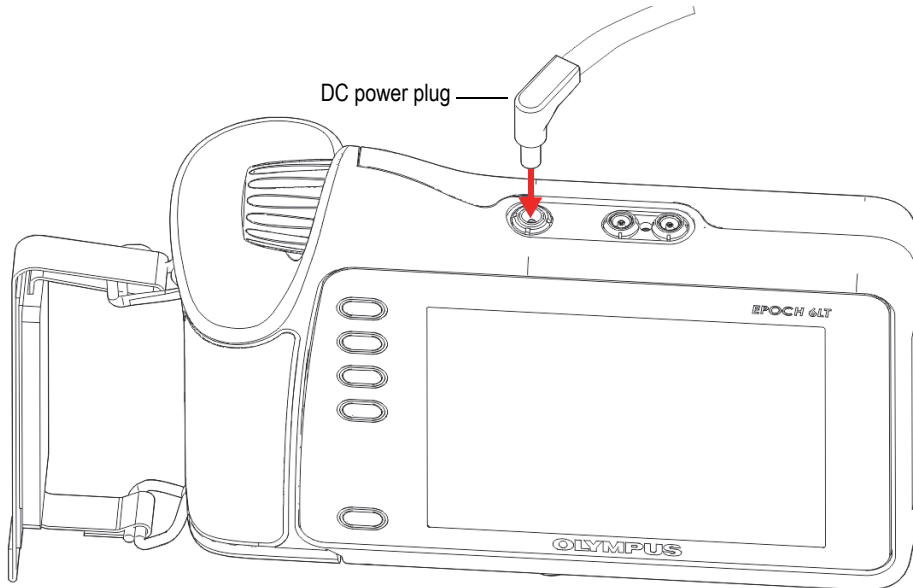

**Figure 3-1 Connecting the DC power plug**

2. Insert the other end of the AC power cord into the AC connector on the AC charger/adaptor (see Figure 3-2 on page 37).

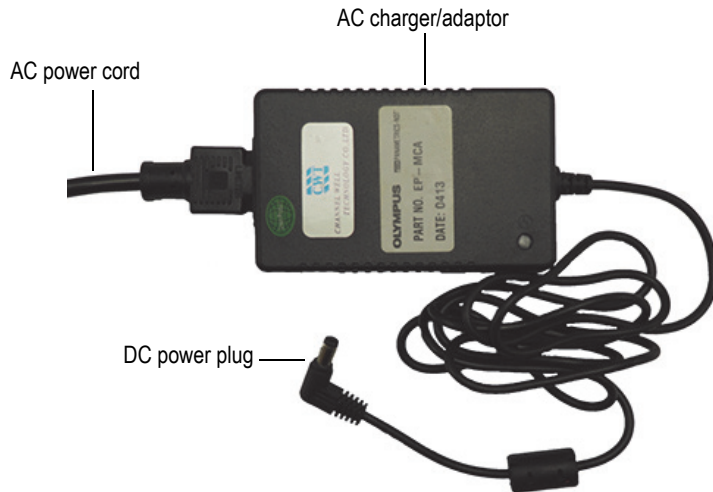

**Figure 3-2 AC charger/adaptor**

3. Insert the AC power cord plug into a suitable AC mains outlet.

## 3.4 Opening the Data Port Cover

The data port contains the EPOCH 6LT I/O connections.

### To open the data port cover

1. Press the cover release button and slide it towards the bottom of the instrument to unlock the data port cover (see Figure 3-3 on page 38).

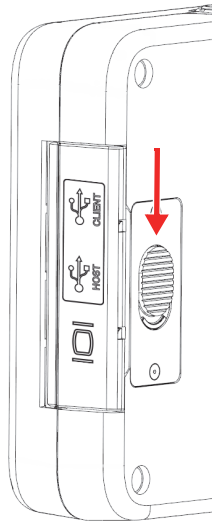

**Figure 3-3 Data Port cover release button**

2. Swing up the cover to its fully open position (see Figure 3-4 on page 38).

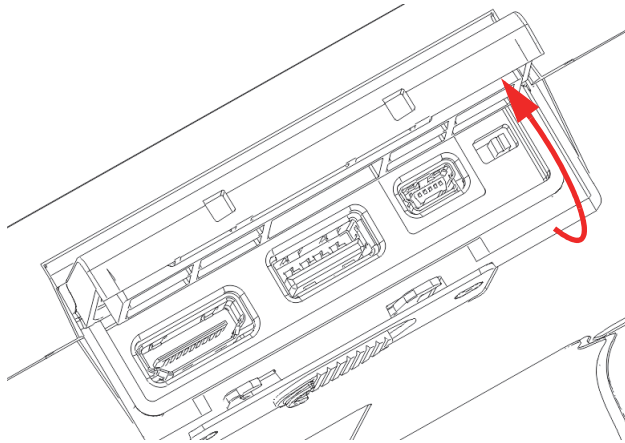

**Figure 3-4 Data port—cover open**

---

## 4. Maintenance and Troubleshooting

---

This chapter details the maintenance tasks to be performed on the EPOCH 6LT ultrasonic flaw detector and provides a troubleshooting guide.

### 4.1 Battery Replacement

Perform the following procedure to replace the battery.

#### To remove the battery

1. Hold the EPOCH 6LT so the battery compartment cover is facing up as shown in Figure 4-1 on page 39.
2. Press the battery compartment cover release button and slide it to the right.

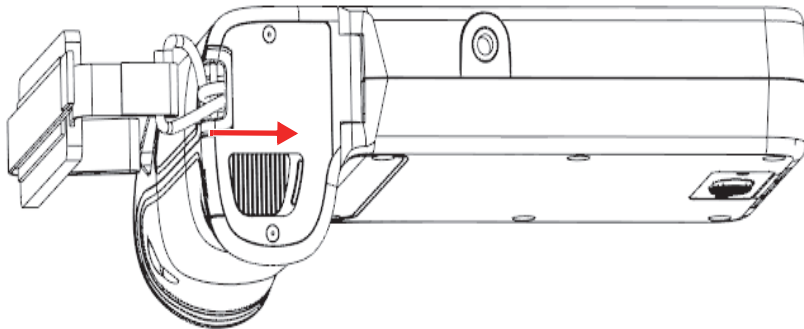

**Figure 4-1 Battery compartment cover release button**

3. Lift the cover to the fully open position (see Figure 4-2 on page 40).

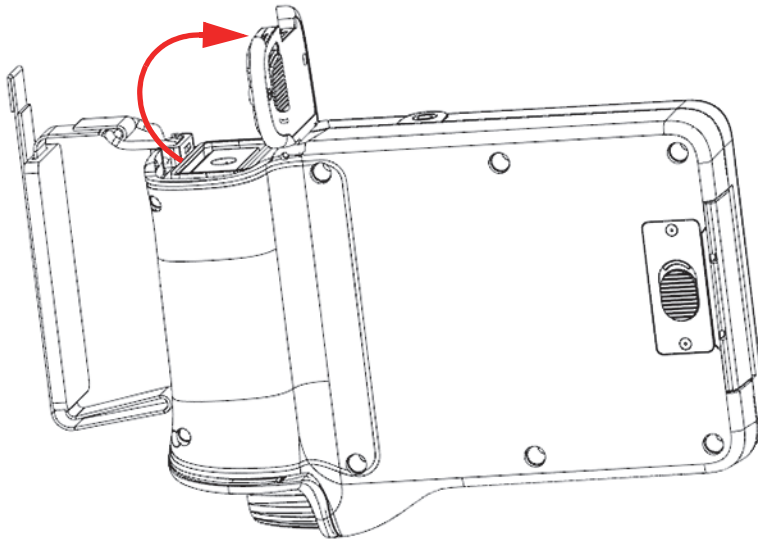

**Figure 4-2 Battery compartment—cover open**

4. Grasp the tab on the battery and pull it up to release and remove the battery (see Figure 4-3 on page 41).



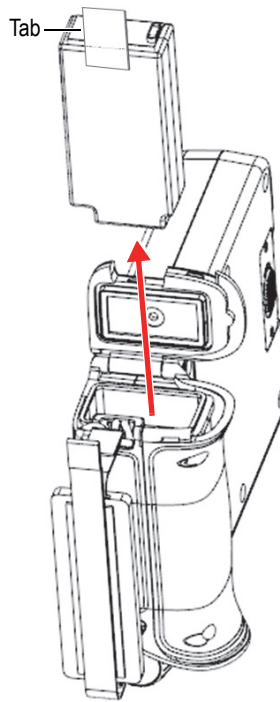

**Figure 4-3 Battery removal**

### **To replace the battery**

1. Align the contacts of a fully charged battery with the contacts inside the EPOCH 6LT battery compartment, and then insert the battery into the battery compartment.  
The battery compartment is keyed so that the battery can only be fully inserted if it is correctly inserted in the keyway.
2. Fold the battery tab away from the battery compartment cover seal before closing.
3. Close the battery compartment cover.
4. Press and slide the release button to the left to securely lock the cover.

## 4.2 Instrument Cleaning

When needed, use a cloth dampened with mild soap and water to carefully wash the instrument.

## 4.3 Seal Verification

The EPOCH 6LT contains seals that are used to protect the instrument's internal hardware from the environment. These include the following:

- Battery compartment cover seal
- Data port cover seal

Regularly clean and verify the state of the above seals to ensure the integrity of the hardware protection.

## 4.4 Display Protection

The EPOCH 6LT includes a clear-plastic sheet to protect the display window. Leave the clear-plastic sheet in place when using the instrument to continuously protect the display. Clear-plastic sheet replacements are available from Olympus in packages of 10 (P/N: 600-DP [U8780297]).



### CAUTION

The display window is permanently bonded to the front panel of the instrument case to fully seal the instrument. If the display window is damaged, the entire front panel, including the direct-access keypad, must be replaced.

---

## 4.5 Annual Calibration

Olympus recommends that you send your EPOCH 6LT once a year to an Olympus service center for annual calibration. Contact Olympus for details.

## 4.6 Troubleshooting

Table 5 on page 43 lists some problems that may arise, possible causes, and suggested solutions.

**Table 5 Troubleshooting guide**

<b>Problem</b>	<b>Possible cause</b>	<b>Solution</b>
After a software update, the instrument does not start when pressing the Power button.	Interrupted, incomplete, or corrupted software update.	Toggle the Reset switch located under the data port cover. Then turn the instrument on and use the PC upgrade software to reinstall the upgrade files.
Several software functions are unavailable.	The Cal Lock function is active, locking all front panel keys.	Turn the instrument off and on to unlock the keys.
The instrument freezes on the Olympus splash screen during start up.	File or parameter value corruption.	Perform a hard reset by turning the instrument off, pressing and holding the Tab button, and turning the instrument back on. Note that all saved files will be lost during this process.
No signal is received when connected to one or more transducers.	Transducer(s) connected to the incorrect LEMO 00 connector(s).	For single crystal pulse-echo inspections, ensure the transducer is connected to the transmit (red) connector. For dual or through-transmission inspections, ensure the transmitting transducer or cable is connected to the transmit (red) connector and the receiving transducer or cable is connected to the receive (blue) connector.



## Appendix A: Specifications

This appendix outlines the specifications for the EPOCH 6LT and its accessories.

**Table 6 General specifications**

Parameter	Specifications
User interface languages	English, Spanish, French, German, Japanese, Chinese, Portuguese, Russian, Italian
Transducer connections	LEMO 00
Data storage	100 000 IDs onboard
Battery type	Single lithium-ion rechargeable standard
Battery life	6 h (lithium-ion)
Power requirements	AC Mains: 100 VAC to 120 VAC, 200 VAC to 240 VAC, 50 Hz to 60 Hz
Current consumption	2.5 A
Power consumption	60 W
Display type	Full VGA (640 × 480 pixels) transfective color LCD, 60 Hz update rate
Display dimensions (W × H, diag.)	117 mm × 89 mm, 146 mm (4.62 in. × 3.49 in., 5.76 in.)
Overall dimensions (W × H × D)	209 mm × 128 mm × 36 mm, 58 mm at hand grip (8.2 in. × 5 in. × 1.4 in., 2.3 in. at hand grip)
Weight	890 g (1.95 lb), including lithium-ion battery

**Table 7 Pulser**

Parameter	Specifications
Pulser	Tunable square wave
PRF	10 Hz to 2000 Hz in 10 Hz increments
Energy settings	100 V, 200 V, 300 V, or 400 V
Pulse width	Adjustable from 25 ns to 5000 ns (0.1 MHz) with PerfectSquare technology
Damping	50 $\Omega$ , 400 $\Omega$

**Table 8 Receiver**

Parameter	Specifications
Gain	0 db to 110 dB
Maximum input signal	20 Vpk
Receiver input impedance	400 $\Omega$ $\pm$ 5 %
Receiver bandwidth	DC to 26.5 MHz at -3 dB (Standard version) 0.2 MHz to 26.5 MHz at -3 dB (EN12668 compliant version)
Digital filter settings	8 digital filter sets (standard version) 7 digital filter sets (EN12668 compliant version)
Rectification	Full-wave, Positive Half-wave, Negative Half-wave, RF
System linearity	Horizontal: $\pm$ 0.5 % FSW
Resolution	0.25 % FSH, amplifier accuracy $\pm$ 1 dB
Reject	0 % to 85 % FSH in 1 % increment positions
Amplitude measurement	1.25 % to 110 % full screen height
Measurement rate	Equivalent to PRF in all modes (single shot)

**Table 9 Calibration**

Parameter	Specifications
Automated calibration)	Velocity, Zero Offset Straight Beam (first back wall or echo-to-echo) Angle Beam (Soundpath or Depth)
Test modes	Pulse Echo, Dual, or Through Transmission

**Table 9 Calibration (continued)**

Parameter	Specifications
Units	Millimeters, inches, or microseconds
Range	4.31 mm to 6700 mm at 5900 m/s (0.2320 in./ $\mu$ s)
Velocity	635 m/s to 15 240 m/s (0.0250 in./ $\mu$ s to 0.6000 in./ $\mu$ s)
Zero offset	0 $\mu$ s to 750 $\mu$ s
Display delay	-10 $\mu$ s to 2203 $\mu$ s
Refracted angle	0° to 85° in 0.1° increments, then jumps to 90°

**Table 10 Gates**

Parameter	Specifications
Measurement gates	2 fully independent flaw gates
Gate start	Variable over entire displayed range
Gate width	Variable from 0.040 $\mu$ s to end of displayed range
Gate height	Variable from 2 % to 95 % full screen height in 1 % increments
Alarms	Positive and Negative Threshold/Curve, Minimum Depth (Gate 1 and Gate 2)

**Table 11 Measurements**

Parameter	Specifications
Measurement display locations	5 locations available (manual or auto selection)
Gate (1, 2)	Thickness, Soundpath, Projection, Depth, Amplitude, Time-Of-Flight, Min./Max. Depth, Min./Max. Amplitude
Echo-to-echo	Standard Gate 2 - Gate 1
Other measurements	Overshoot (dB) value for DGS/AVG, ERS (equivalent reflector size) for DGS/AVG, AWS D1.1/D1.5 A, B, C, D values, Reject Value, Echo to Ref dB values
DAC/TCG	Standard
DAC points	Up to 50 points, 110 dB dynamic range
Special DAC modes	Custom DAC (up to 6 curves), 20–80 % View
Curved surface correction	Standard OD or Bar correction for Angle Beam measurements

**Table 11 Measurements (continued)**

Parameter	Specifications
Corrosion (optional)	Zero-cross measurement algorithm, V-Path correction, Single or Echo-to-Echo

**Table 12 Environmental ratings**

Parameter	Specifications
IP rating	Ingress protection engineered to IP67 (dust tight and water submersion) and IP65 (dust tight and water jets) per IEC 60529-2004 ( <i>Degrees of Protection Provided by Enclosures – IP Code</i> ).
Explosive atmosphere	MIL-STD-810F, Method 511.4, Procedure 1
Shock tested	MIL-STD-810F, Method 516.5, Procedure I, 6 cycles each axis, 15 g, 11 ms half sine
Vibration tested	MIL-STD-810F, Method 514.5, Procedure I, Annex C, Figure 6, general exposure: 1 hour each axis
Operating temperature	-10 °C to 50 °C (14 °F to 122 °F)
Battery storage temperature	0 °C to 50 °C (32 °F to 122 °F)
Altitude	Designed to function safely up to 2000 m
Mains supply voltage fluctuations	Designed to function safely at $\pm 10$ % of the nominal voltage
Transient overvoltages	Designed to function safely with transient overvoltages up to the levels of Overvoltage Category II
Temporary overvoltages	Designed to function safely with temporary overvoltages occurring on the mains supply
Pollution degree	Designed to function safely at a pollution degree of 2

**Table 13 Instrument inputs and outputs**

Parameter	Specifications
USB ports	(1) USB 1.1 Full Speed Host (Type A) (1) USB 2.0 Full Speed Client (Type Mini B)
Video output	1 digital video output



## Appendix B: Parts List

This appendix details the complete parts list, including optional accessories.

**Table 14 EPOCH 6LT basic kit<sup>a</sup>**

Part number	U8 or Q number	Description
EP6LT-UEE OR EP6LT-UEE-EN12	N/A	EPOCH 6LT base unit  EPOCH 6LT base unit with EN12668-1:2010 Group 2 Certificate
BATT-10025	Q7600001	EPOCH 6LT lithium-ion rechargeable battery
HNDL-10018-0001	Q7790068	EPOCH 6LT wrist strap
EPLTC-C-USB-A-6	U8840031	USB Cable, mini A to mini B
PACK-10125-0000	Q7640003	EPOCH 6LT transport case

- a. Spares can be purchased.

**Table 15 EPOCH 6LT optional accessories**

Part number	U8 or Q number	Description
600-DP	U8780297	EPOCH 6LT display protectors (10 Pack)
EP6LT-KIT-ROPE	Q7790069	EPOCH 6LT rope access accessory kit
EP4/CH	U8140055	EPOCH Series chest harness
EP6LT-STAND	Q7790070	EPOCH 6LT desktop stand
EPXT-EC-x	N/A	EPOCH Series external charging base with power cord

**Table 16 Software options**

<b>Part number</b>	<b>U8 or Q number</b>	<b>Specifications</b>
EP6LT-AWS	Q1400007	AWS D1.1/D1.5 weld rating software option
EP6LT-CORRSN	Q1400008	Corrosion module software option
EP6LT-BEA	Q1400009	EPOCH 6LT back wall echo attenuator software option

---

## List of Figures

---

Figure i-1	Labels location .....	1
Figure 1-1	EPOCH 6LT Li-ion battery .....	21
Figure 1-2	AC charger/adaptor .....	22
Figure 1-3	USB data cable .....	23
Figure 2-1	External connectors .....	27
Figure 2-2	Color-coded LEMO connectors .....	28
Figure 2-3	Battery compartment—cover closed .....	29
Figure 2-4	Data port connectors and reset switch .....	29
Figure 2-5	Accessory mount .....	30
Figure 2-6	Wrist strap mounts .....	31
Figure 2-7	EPOCH 6LT front panel .....	32
Figure 2-8	Adjustment knob .....	33
Figure 3-1	Connecting the DC power plug .....	36
Figure 3-2	AC charger/adaptor .....	37
Figure 3-3	Data Port cover release button .....	38
Figure 3-4	Data port—cover open .....	38
Figure 4-1	Battery compartment cover release button .....	39
Figure 4-2	Battery compartment—cover open .....	40
Figure 4-3	Battery removal .....	41



---

## List of Tables

---

Table 1	Content of the rating label .....	2
Table 2	EPOCH 6LT ultrasonic flaw detector components .....	20
Table 3	Region specific power cord options .....	22
Table 4	EPOCH 6LT charging base .....	24
Table 5	Troubleshooting guide .....	43
Table 6	General specifications .....	45
Table 7	Pulser .....	46
Table 8	Receiver .....	46
Table 9	Calibration .....	46
Table 10	Gates .....	47
Table 11	Measurements .....	47
Table 12	Environmental ratings .....	48
Table 13	Instrument inputs and outputs .....	48
Table 14	EPOCH 6LT basic kit .....	49
Table 15	EPOCH 6LT optional accessories .....	49
Table 16	Software options .....	50



---

# Index

---

## A

AC adaptor connector 20, 28, 36  
AC charger adaptor 21  
accessories  
    optional 49  
    standard 21  
adjustment knob 20, 33  
annual calibration 42  
Australia, RCM compliance 2

## B

batteries  
    precautions 10  
battery  
    charger 24  
    conditioning 25  
    description 21  
    replacement 39

## C

cable, USB data 23  
calibration, annual 42  
CAUTION signal word 8  
cautions  
    instrument compatibility 6  
    modification prohibited 6  
CE (European Community) 11  
CE marking 2  
charger adaptor, AC 21  
charger, battery 24  
charging the battery 24, 36  
China RoHS 3, 12  
cleaning the instrument 42  
compliance  
    EMC directive 13

FCC (USA) 13

ICES-001 (Canada) 14

RCM (Australia) 2

components, flaw detector 20

conditioning the battery 25

connectors

    AC adaptor 20, 28, 36

    digital video 30

    LEMO transducer 20, 28, 43

    mini USB 30

    USB 30

## D

danger notes

    electric shock 4

DANGER signal word 7

DC adaptor polarity symbol 3

digital video connector 30

display protection 42

disposal, equipment 11

## E

electric shock, danger note 4

EMC directive compliance 13

equipment disposal 11

European Community (CE) 11

## F

FCC (USA) compliance 13

flaw detector components 20

## G

general specifications 45

## I

ICES-001 (Canada) compliance 14

important information 5

IMPORTANT signal word 8

- instruction manual 5
- instrument
  - cleaning 42
  - powering on/off 35
- IP rating 48
- K**
- keys and indicators 31
- knob, adjustment 20, 33
- Korea Communications Commission (KCC) 13
- Korean standard 3
- L**
- labels 1
- LEMO transducer connectors 20, 28, 43
- M**
- manual, instruction 5
- mini USB connector 30
- modification, instrument 6
- N**
- NOTE signal word 8
- notes, information
  - signal words 8
- O**
- o-ring gaskets and seals, verifying 42
- Olympus technical support 15
- optional accessories 49
- P**
- package content 19
- parts list 49
- polarity symbol, DC adaptor 3
- power button 32
- power cord, region specific 22
- powering on/off 35
- precautions
  - battery 10
  - safety 8
- R**
- rating label, location 1
- rating, ingress protection 48
- RCM mark 2
- repair, instrument 6
- replacement, battery 39
- RoHS symbol 3, 12
- S**
- safety
  - instrument compatibility 6
  - misuse of instrument 5
- precautions 8
- signal words 7
- symbols 7
- serial number format 4
- signal words
  - information notes 8
  - IMPORTANT 8
  - NOTE 8
  - TIP 8
  - safety 7
  - CAUTION 8
  - DANGER 7
  - WARNING 7
- software options 50
- specifications 45
  - calibration 46
  - gates 47
  - general 45
  - measurements 47
  - pulser 46
  - receiver 46
- standard accessories 21
- support information, technical 15
- symbols 1
  - CE 2
  - DC adaptor polarity 3
  - Korean standard 3
  - RCM (Australia) 2
  - RoHS 3, 12
  - safety 7
  - WEEE 2
- T**
- technical support 15
- TIP signal word 8
- U**
- USB connector 30
- USB data cable 23
- USB drive 23
- use, intended 5
- W**
- WARNING signal word 7
- warning symbols
  - general 7
  - shock hazard 7



warnings  
  general 9  
  misuse of instrument 5  
warranty information 14

waste electrical and electronic equipment 11  
WEEE directive 11  
  symbol 2

