

Operating manual

**High Power Ring Light
HPRL**

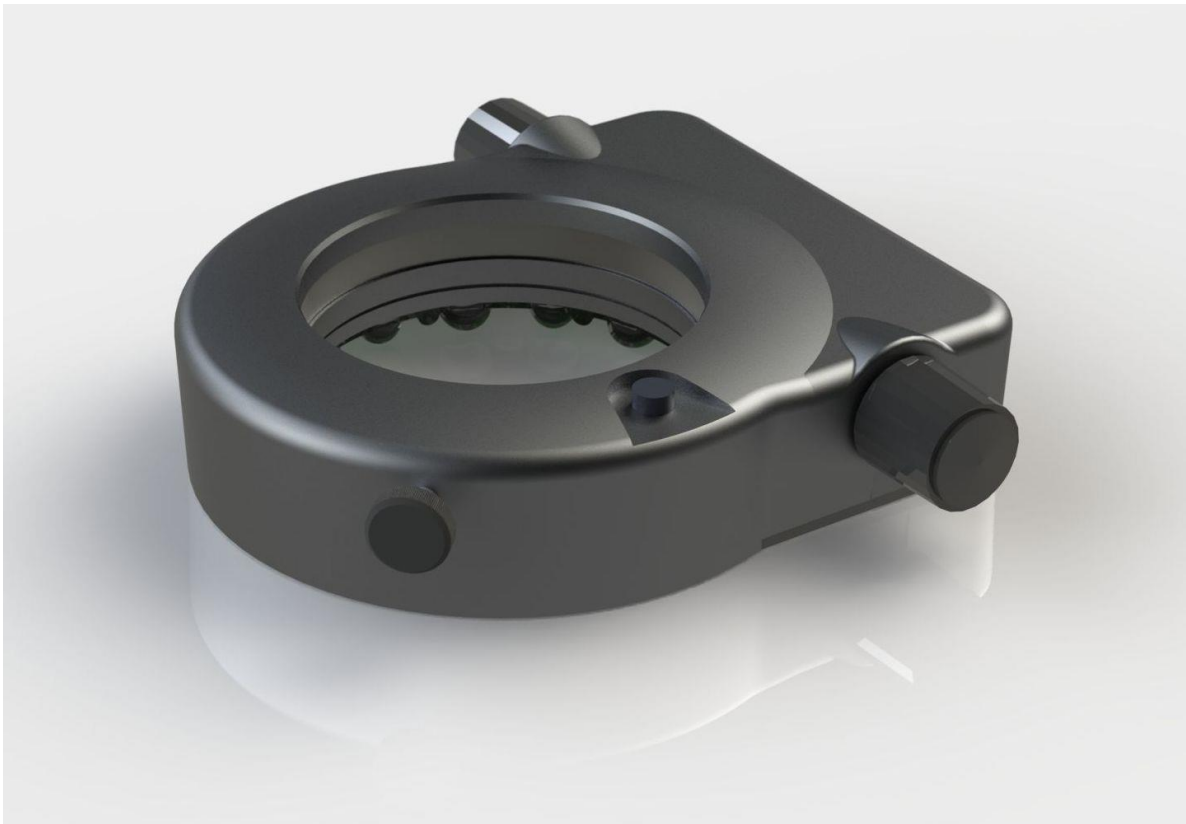

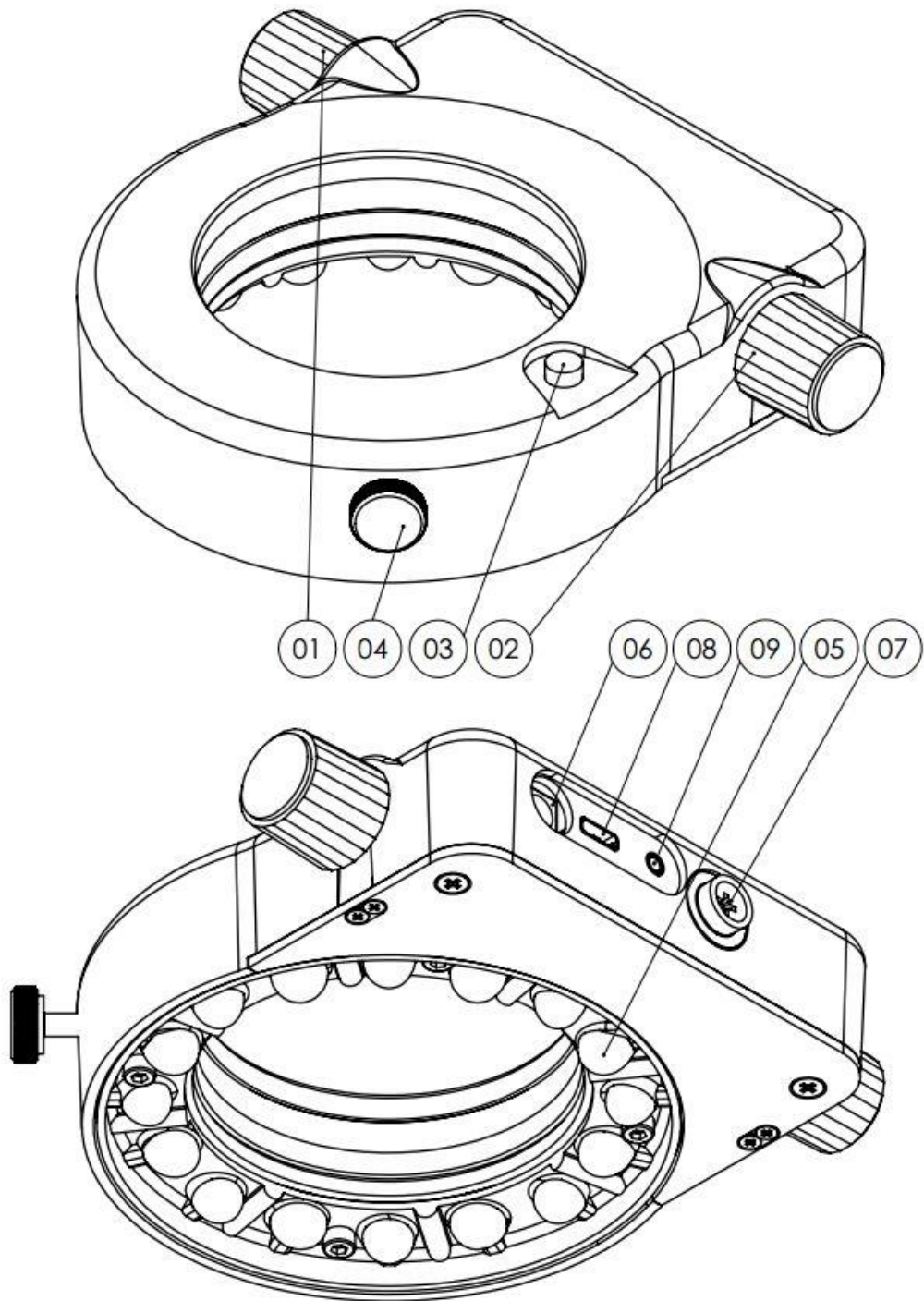

- 1Left rotary encoder (segment selection)
- 2Right rotary encoder (brightness control)
- 3On/off switch
- 4Clamping screw for fastening
- 5Ring lens
- 6DC socket for power supply
- 7ESD connector
- 8USB type C port (optional)
- 9Socket for foot switch (optional)

Designated use

This product has been developed and is intended for illumination purposes in the sector of stereo microscopy for industry and laboratory use. The applicable standards and guidelines are listed in the Chapter "Technical data".

This product is attached to the microscope lens and illuminates the underlying objects. A lens focuses the light to the desired working distance.

We would like to say thank you for choosing to purchase this high-quality product and wish you lots of success whilst using it.

Instructions for your safety

The following danger symbols are used in this operating manual:



Warning of a danger area! Caution, please refer to documentation!



Warning of dangerous electrical voltage!



Warning of hot surfaces!



ATTENTION: Dangerous optical radiation! Do not look into the light!

This chapter deals with safety instructions that must be complied with when using the device. In your own interests, please comply with all safety instructions that are listed on the device and in this manual.



The operating instructions must be read before using the device. It is recommended to store the operating instructions close to the device to ensure that it can be read immediately by the user in case of need. The user must inform a responsible person or the manufacturer immediately if there are any changes in the operating behaviour or to any safety-relevant device components. The operator is responsible for the correct use of the product and for the training of the user. The generally application legal national safety and accident prevention regulations must be complied with in addition to the supplementary user guidelines of the operator. The manufacturer is not liable for any damages due to incorrect operation or non-compliance with the danger instructions!



Never open the device or its components, unless specifically indicated in this manual as you could otherwise risk physical injury or damage. If necessary, contact your retailer. Technical modifications to the device are not permitted under any circumstances and repairs should only be carried out by the manufacturer or authorised service points. Only original spare parts must be used. Only use original spare parts approved by the manufacturer for this product. Operate this product only with the supplied power supply adapter and place the adapter so that it can be quickly disconnected from the mains.

Do not operate the device in the vicinity of water or in rooms with extreme humidity. Do not spill any liquids onto the device and do not push any foreign bodies into the product, you could be electrocuted or cause damage to the device. Do not position any flammable materials in the direct vicinity of the device. The device must be kept away from all sources of heat and is not approved for use in explosion hazard areas! The device may only be used in closed rooms.

Never allow the device to operate unsupervised! The device may only be operated with the specified supply voltage and the power supply adapter included in the scope of delivery. Only use as much brightness as required for working. A higher brightness setting can irritate the eyes, stresses the object and also reduces the service life of the device.



Always keep the ventilation openings of the device free to avoid causing any overheating. Ensure that the free air circulation is not hindered by anything and that there is a sufficiently large gap between the ventilation openings and other objects. Keep the environment of the device clean (above all, dust and lint-free), so that any device fans cannot suck in any dirt.



ATTENTION: dangerous optical radiation, do not look into the light, can injure your eyes

The device emits light with a high intensity! Never look directly into the lamp or any light-emitting device openings as you will risk injury to the eyes. The emitted light is absorbed by materials and converted into heat. Never cover the light emission aperture of the device with the hand, any other parts of the body or any materials. To illuminate objects correctly, always ensure there is a distance appropriate to avoid thermal damage or fire.

Before cleaning, disconnect the product from the mains and allow it to cool for at least 15 minutes. Use a dry cloth for cleaning or a cloth moistened with water or a 5% ethyl or isopropyl alcohol solution, but do not use combustible or flammable liquids under any circumstances. Allow the device to dry thoroughly before use. If any liquid penetrates the device accidentally, pull the plug immediately and bring the device to a service point. If dust has collected on the ventilation openings, it must be removed carefully. Excessively intensive cleaning or the use of solutions that are too concentrated can lead to scratches, discoloration or other damage to the surfaces of the device.

Operation

Unpack this product and remove any protective film. Save the packaging.



Carefully read the complete operating instructions and observe the safety instructions under all circumstances!



Attention: If the encoders do not behave as described here, then perhaps the left-handed mode has been activated as described in the "Settings" chapter (S3), whereby the functions of the two encoders are interchanged. If at any point you are not sure, you can perform a factory reset, which is also described in the "Settings" chapter.



Use only the supplied power supply adapter and check if it is suitable for your voltage supply.

Assembly of the ring lens

Select the working distance suitable for your application by placing the lenses A or B above the LEDs. Lense A is factory preset.

Lense A (left of divider C) for working distances between 45-130 mm.

Lense B (right of divider C) for working distances between 80-300 mm.

The areas overlap, whereby from an 80 mm working distance the B lense produces more brightness.



Observe all safety instructions before moving the ring lens. Disconnect the ring light from the mains. Make sure the LEDs cannot illuminate.

Loosen the 4 D screws using the SW2.5 Allen key and lift the ring lens gently. Do not touch any LEDs or other electronic components. Now place the desired lenses A or B over the LEDs and tighten the 4 D screws carefully again. Make sure that the screws are not tightened too tightly.



Simply rotating the ring lens without lifting it can destroy the LEDs.

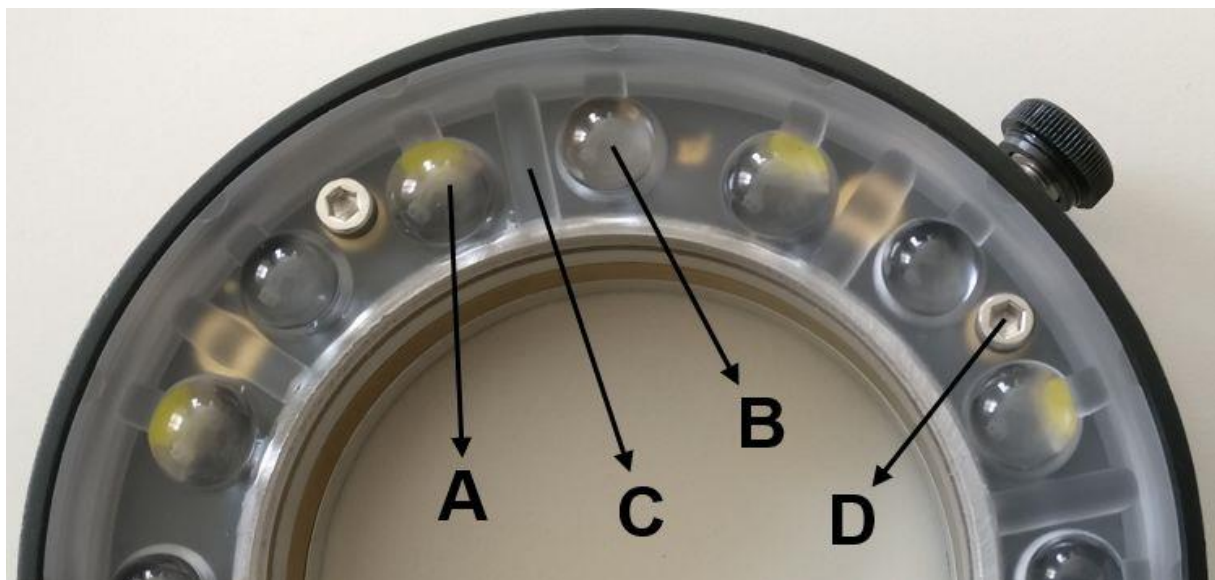

ESD workplace

When working with ESD-sensitive components, an appropriate cable must be connected to the ESD socket (7). This serves to compensate the workplace potential.

On/off switch

Select the required country adapter and plug the supplied power supply adapter into the mains outlet. Plug the supplied adapter to the socket (6) to switch on the power supply. The lamp can be switched on and off by briefly pressing the button (3).

Brightness control

The brightness can be changed by turning the right encoder (2). By briefly pressing the same encoder, a previously stored brightness value can be recalled. To set the memory value, first set the desired brightness and the illumination pattern and then press the encoder (2) for approx. 2 seconds until the LEDs flash briefly.

Segment selection

Press the left encoder (1) to select the following LED patterns:

Full circle | Semicircle | Quarter circle | Single LED | 2 Quarter circles opposite

Rotating the same encoder (1) rotates the selected LED light image in 1/8th circular steps. It can be rotated in both directions.

Autorotation

If a luminous image is selected, an approx. 2 second long press on the encoder (1) starts the autorotation. The rotation speed can be changed in this mode by turning the encoder (1). The autorotation is terminated by briefly pressing (1) once.

Mounting and using the polarising filter (optional)

To attach polarisation filters or diffusers, screw the corresponding accessories from below into the thread of the ring light. Make sure that the accessories are not screwed too tightly. Check that the polarising filter cannot come loose from the ring light from twisting the analyser.

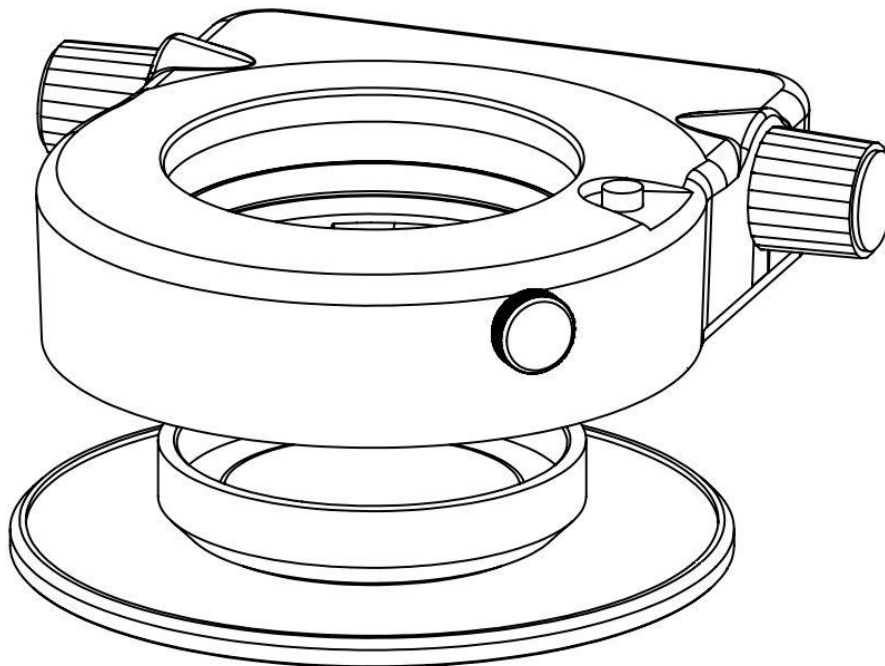

USB (optional)

Optional USB type C is available for remote control and integration into systems. For the commands please see the attached document.

Foot switch (optional)

A connection for a footswitch is available as an option. The lamp can be switched on and off with this.

Settings

You can enter the setup menu by pressing both encoders (1 + 2) approx. 4 seconds long.

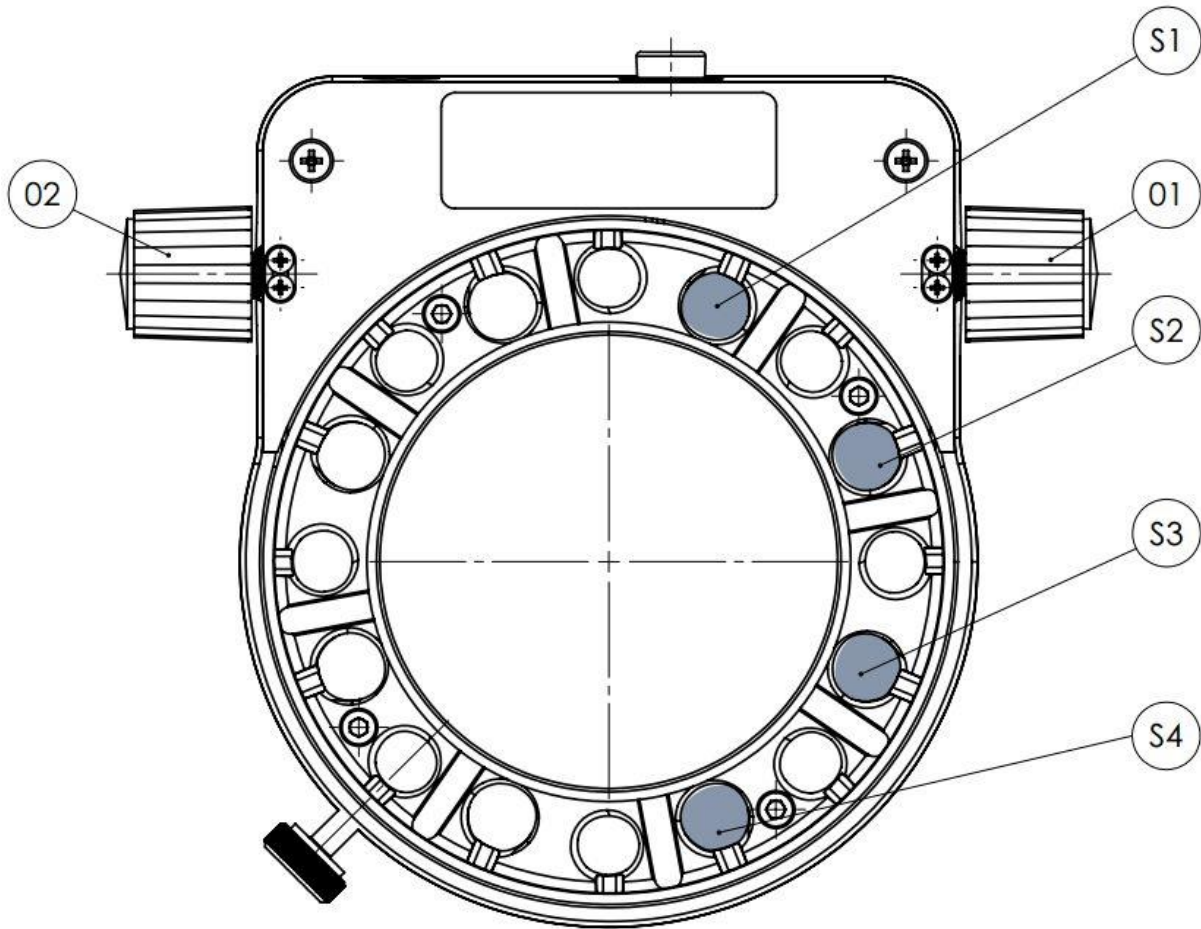

There are 4 setting points for which one LED (S1-S4) is available for each. By turning the encoder (1), you can control the desired setting point. Pressing the same encoder (1) changes the value of this setting. The set value is indicated by the flashing or lighting of the respective LED.

Setup	LED constantly lit (default)	LED flashes
S1	Safety mode: Light OFF after connecting to the power supply. After power on the last lighting scenario follows	Connector strip mode: Light ON after connecting to the power supply. Automatic start with the saved lighting scenario
S2	Logarithmic brightness control	Linear brightness control from 1-100%
S3	Brightness encoder right and segment selection left	Brightness encoder left and segment selection right
S4	Brightness control by analogue current setting	Brightness control over the duty factor of a PWM signal

The default settings are defined in the first column ("LED constantly lit")

By prolonged pressing of both encoders (1 + 2) the settings are saved and the setup menu is exited.

Factory reset

To do so, pull the power supply (6) and then press and hold the on/off switch (3) while you plug the power supply back in. Press and hold the on/off switch until the LEDs flash briefly several times.

Technical data

	HPRL
Dimensions (WxDxH)	approx. 107x128x31mm without protruding parts
Weight	approx. 300g (without power supply adapter and accessories)
Illumination source	8 high power LEDs
Colour temperature	Approx. 5800 K
Centre brightness	approx. 210kLux at 50mm working distance for lenses A approx. 170kLux at 90mm working distance for lenses B
Lifespan L ₇₀	approx. 25,000 hrs.
Cooling	passive (without fan)
Power supply	24VDC 300 mA
Power consumption	approx. 8 Watt
Operating conditions	10-40°C, max 75% non-condensing humidity, max. 2000 m altitude 800-1060hPa
Storage in the packaging	10-40°C, max 75% relative humidity at 35° non-condensing humidity
Transport in the packaging	-40 to +70°C
Rear connections	DC socket ESD port USB type C (optional) 2,5mm stereo jack for footswitch (optional)
Mounting	Clamping to lens diameter 66 mm
Approval (CE)	EMC Directive 2014/30/EC LVD 2014/35/EC (Low Voltage Directive for power supply adapters) RoHS 2011/65/EC (Restriction of Hazardous Substances Directive) Risk group 0 according to EN62471 (exempt, no risk)

Disposal

Do not dispose of the product in household waste, take it to the appropriate collection and disposal points. Comply with the national and local disposal guidelines and laws. Please help to keep our environment clean.

The development of this product is subject to continuous development. Although we try to keep this operating manual up to date, we reserve the right to change device data at any time without prior notice. The operating manual is produced subject to errors and printing errors.